

SPECIFICATION SUBMITTAL VENTILATION FANS

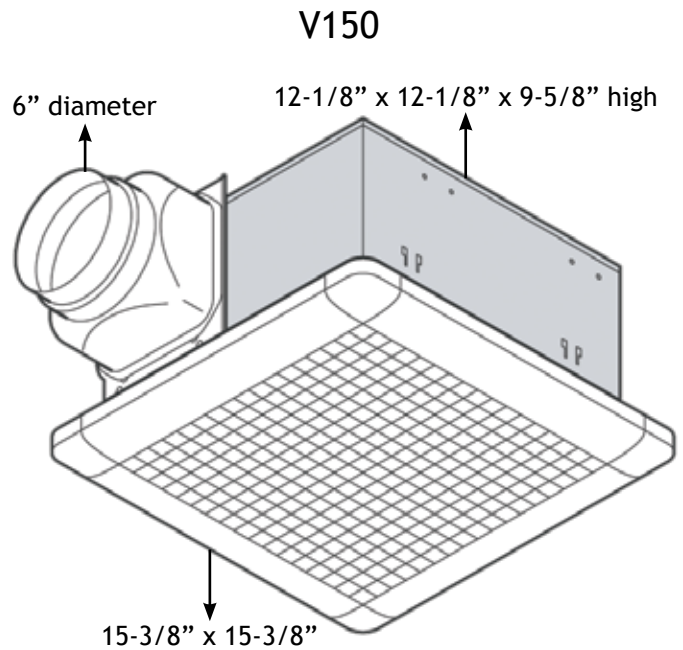

Application Performance

Model	CFM @ Static Pressure (in. w.g.)						CFM/Watt @ 0.1
	0.0	0.1	0.2	0.3	0.4	0.5	
V50	72	58	42	19	0	0	4.5
V80	93	83	71	54	25	0	5.1
V110	122	112	101	86	60	17	4.6
V150	174	150	123	98	76	53	4.5

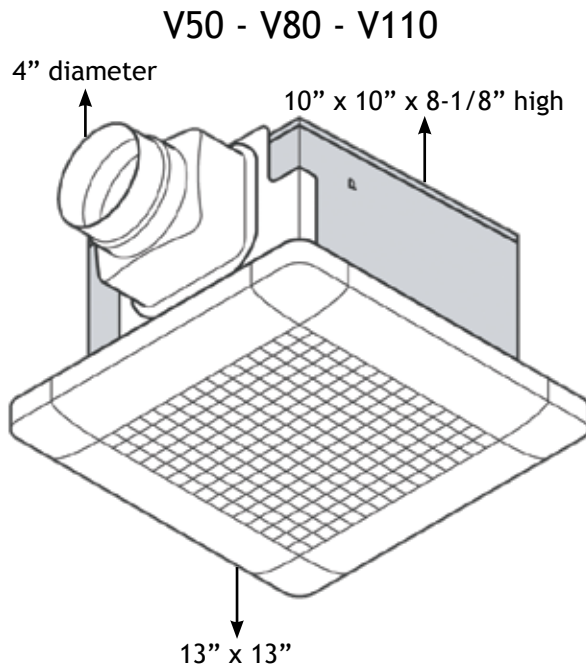

HVI Certified Performance

Model	CFM @ 0.1" Ps	Watts	Sones @ 0.1" Ps	CFM @ 0.25 Ps	Watts
V50	50	12.9	<0.3	31	11.8
V80	80	16.1	<0.3	60	15.2
V110	110	24.2	0.8	93	23.0
V150	150	32.7	<0.3	110	32.0

Typical Specifications:

Ventilating fan shall be RenewAire V-Series mounted in the ceiling. The fan shall have a 5 year limited warranty. The fan shall be HVI Certified at 0.1 inch water gauge for [50 - 80 - 110 - 150] CFM with a power consumption not to exceed [12.9 - 16.1 - 24.2 - 32.7] Watts. The fan motor shall have a heat-sink motor mount providing low temperature operation. The motor shall be UL and cUL Listed with impedance protection plus additional thermal protection. The fan shall be Energy Star Qualified. A "debris cover" shall be provided so that the blower/motor need not be removed during construction.

Electrical

Model	120V - 60Hz
V50	0.12 Amps
V80	0.15 Amps
V110	0.21 Amps
V150	0.29 Amps

Weight

Model	Unit Weight	Shipping Weight
V50	7.7 lbs	10.4 lbs
V80	7.7 lbs	10.4 lbs
V110	7.7 lbs	10.4 lbs
V150	12.3 lbs	16.2 lbs

